

**metabo**<sup>®</sup>  
work. don't play.



NEW!

# METAL MASTERS



The Metabo 3-year warranty  
Register online at: [www.metabo.com/xxl](http://www.metabo.com/xxl)

# THE WORLD'S BEST GRINDERS JUST GOT BETTER!

Max. Wheel Diameter					Key Enhancements						
	OLD LINE		NEW LINE		"Cool Flow" Technology	Labyrinth Double Sealed Bearings	Sealed, Encapsulated Switch	Enclosed Carbon Brush Holders	Secure "Racket" Grip	AC/DC Capability	Disc Brake
	Model No.	Order No.	Model No.	Order No.							
4 1/2"	W7-115	606204420	W8-115	600259420	•	•	•	•	•	•	
4 1/2"	W7-115 Quick	600715420	W8-115 Quick	600264420	•	•	•	•	•	•	
5"	W7-125	606205420	W8-125	600263420	•	•	•	•	•	•	
5"	WE9-125 Quick	600925420	WE9-125 Quick	600269420	•	•	•	•	•		
5"	W10-125 Quick	601026420	W11-125 Quick	600270420	•	•	•	•	•	•	
5"	-----	-----	WB11-125 Quick	600274420	•	•	•	•	•	•	•
5"	WE14-125 Plus	601425420	WE14-125 Plus	600281420	•	•	•	•	•		
6"	W10-150 Quick	601051420	W11-150 Quick	600271420	•	•	•	•	•	•	
6"	-----	-----	WB11-150 Quick	600276420	•	•	•	•	•	•	•
6"	WE14-150 Quick	601451420	WE14-150 Quick	600160420	•	•	•	•	•		

See back cover for other available models



# WHY DO PROFESSIONALS CHOOSE METABO GRINDERS?

...FOR THEIR DURABILITY, PRODUCTIVITY, SAFETY AND ERGONOMICS!

## THEY FIGHT OFF HEAT

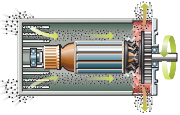

LONG LIFE MOTOR

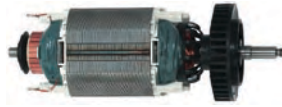

EXTRA EPOXY RESIN COATINGS



THERMAL OVERLOAD PROTECTION

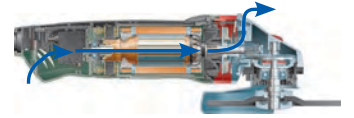

"COOL FLOW" TECHNOLOGY

## THEY FIGHT OFF DUST



WINDING PROTECTION GRID



ENCLOSED CARBON BRUSH HOLDERS



FULLY ENCAPSULATED AC/DC CAPABLE SWITCH



DOUBLE LIPPED LABYRINTH SEALED, DOUBLE SEALED BEARINGS

## THEY WORK FASTER



ELECTRONIC SPEED STABILIZATION



TOOL-LESS GUARD ADJUSTMENT



"QUICK" TOOL-LESS WHEEL CHANGE SYSTEM

## THEY ARE SAFER



SAFETY CLUTCH



POWER INTERRUPTION PROTECTION

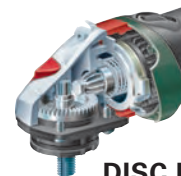

DISC BRAKE

## THEY ARE COMFORTABLE

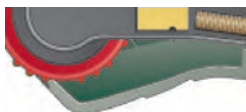

SECURE "RACKET" GRIP



METABO VIBRATECH ANTI-VIBRATION SIDE HANDLE (MVT)



EXCELLENT BALANCE



**Fully encapsulated AC/DC capable switch**

*Extends switch life by eliminating sparking caused by the accumulation of grinding dust.*

**Long life motor with winding protection grid**

- 14 layers of insulation on the copper windings extends life under heavy loads
- Epoxy resin powder coating resists damage from overheating
- Winding protection grid deflects airborne debris and can increase motor life up to 5 times

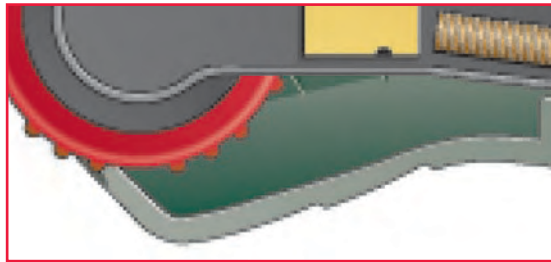
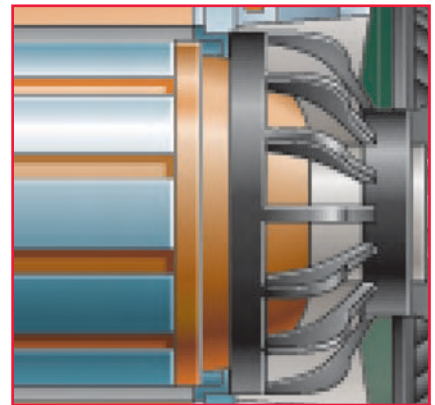

**Secure "Racket" grip**

*Helps operator maintain a secure grip on the tool at all times.*

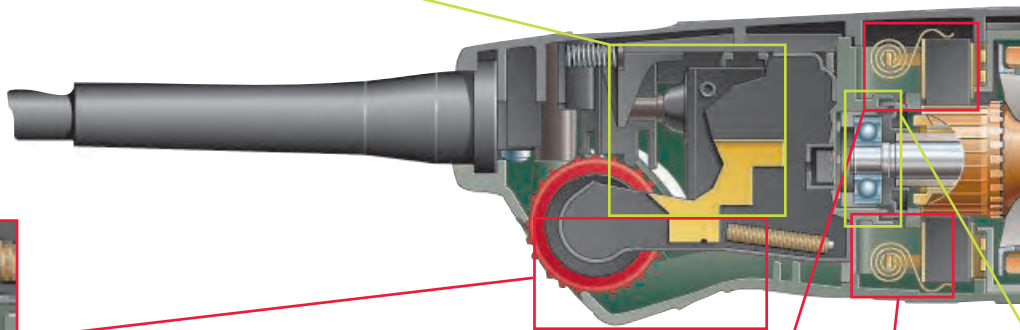

**Enclosed carbon brush holders**

*Nearly eliminates down-time due to "stuck" brushes caused by grinding dust.*

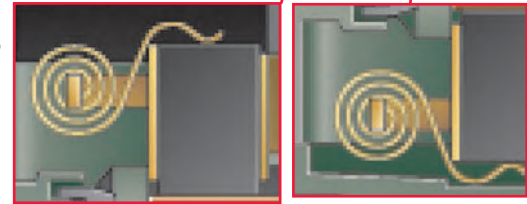

**Metabo Vibrattech anti-vibration handle (MVT)**

*Vibration at the side handle is reduced 60%, significantly reducing the risk of the operator developing "White Finger Syndrome".*

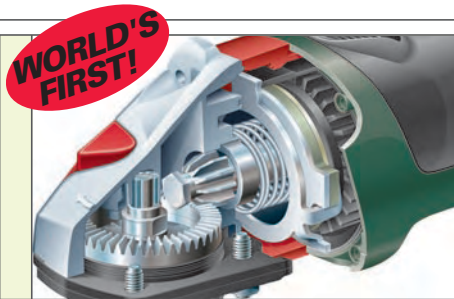

**Disc Brake**

*Metabo's mechanical disc brake, available on the special "WB" models, stops the wheel in less than 3 seconds after the grinder is switched off, thus reducing the risk of accidents.*

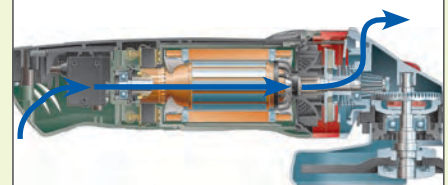

**"Cool Flow" Technology**

*When it comes to motor life, excessive heat buildup is enemy #1. Our new sonically balance fan and enhanced venting system increase the flow of cooling air by 10%-15%.*

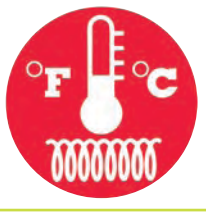

**Thermal overload protection**

*The higher the heat, the greater the risk of burnout. A built in thermocoupler on selected models temporarily "kicks out" the power before the motor kicks out permanently.*

**Aluminum die-cast housing**

*Aluminum is a great conductor of heat. It helps to move damaging heat from inside the tool to the outside.*

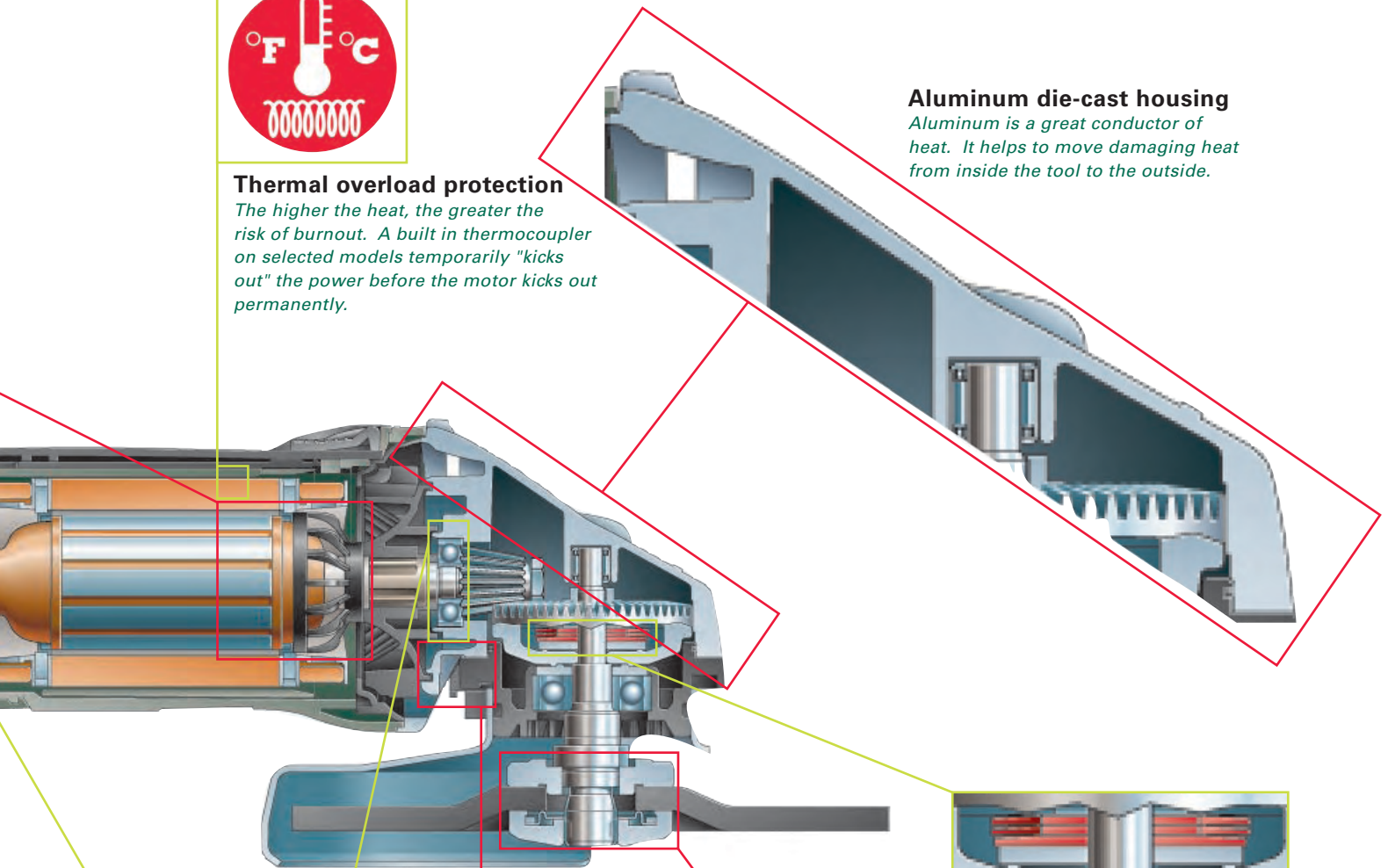

**Safety clutch**

*Helps protect the operator and the tool's gear train from kick-back if a wheel jams.*

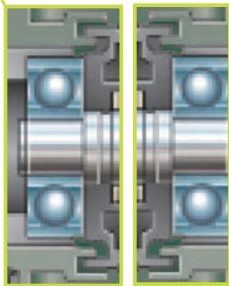

**Double Lipped Labyrinth sealed, double sealed bearings**

*Increases bearing life by preventing harmful dust from getting inside the bearing.*



**Tool-less guard adjustment**



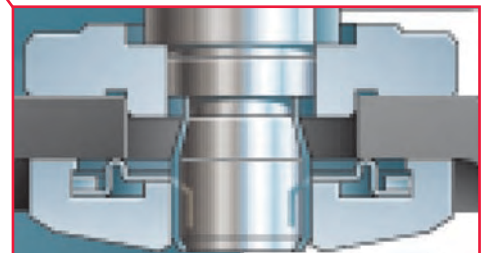

*A properly positioned wheel guard is essential for maximum operator safety. Metabo's engineers have made this fast and easy to do.*





**"Quick" tool-less wheel change system**

*No more time wasted looking for that special wrench!*

# THE COMPLETE NEW RANGE

Model No. Order No.	W8-115 #600259420	W8-125 #600263420	W8-115 Quick #600264420	WE9-125 Quick #600269420
				
AC/DC switch	•	•	•	
Current interruption protection				•
Vario constamatic (VC) electronics				•
Long lasting motor	•	•	•	•
Quick wheel change system			•	•
Switch with lock on capability	•	•	•	•
Spindle lock	•	•	•	•
Low profile aluminum die-cast gear housing	•	•	•	•
Toolless guard adjustment	•	•	•	•
2-position side handle	•	•	•	•
Metabo slip clutch	•	•	•	•
Auto-stop carbon brushes	•	•	•	•
Winding protection grid	•	•	•	•
Maximum Torque	19.5 inch lbs	19.5 inch lbs	19.5 inch lbs	22 inch lbs
Maximum wheel diameter	4 1/2"	5"	4 1/2"	5"
No-load speed (RPM)	10000	10000	10000	3000-10000
Amps	8.0	8.0	8.0	8.5
Rated input watts	800	800	800	950
Arbor size	7/8"	7/8"	7/8"	7/8"
Spindle thread	5/8"-11	5/8"-11	5/8"-11	5/8"-11
Tool weight	5.4 lbs.	5.4 lbs.	5.4 lbs.	5.4 lbs.
Shipping weight	6.3 lbs.	6.2 lbs.	6.2 lbs.	6.2 lbs.
Length	11.75"	11.75"	11.75"	11.75"
Carrying case	344453610 (optional)	344453610 (optional)	344453610 (optional)	344453610 (optional)
Standard Equipment	Side Handle (314000970) Wheel Guard (339202990) Inner Flange (341031290) Face Spanner (623934000) Outer Nut (341101480)	Side Handle (314000970) Wheel Guard (339203010) Inner Flange (341031290) Face Spanner (623934000) Outer Nut (341101480)	Side Handle (314000970) Wheel Guard (339202990) Inner Flange (341031290) Outer Nut (316023840)	Side Handle (314000970) Wheel Guard (339203010) Inner Flange (341031290) Outer Nut (316023840)



Model No. Order No.	W11-125 Quick #600270420 W11-150 Quick #600271420	WB11-125 Quick #600274420 WB11-150 Quick #600276420	WE14-125 Plus #600281420 WE14-150 Quick #600160420
			
AC/DC switch	•	•	
Current interruption protection			•
Thermal overload protection			•
Long lasting motor	•	•	•
Quick wheel change system	•	•	•
Metabo disc brake		•	
Switch with lock on capability	•	•	•
Spindle lock	•	•	•
Low profile aluminum die-cast gear housing	•	•	•
Toolless guard adjustment	•	•	•
2-position side handle	•	•	•
Variable speed controlled by adjusting dial			•
Metabo slip clutch	•	•	•
Auto-stop carbon brushes	•	•	•
Winding protection grid	•	•	•
Electronic soft start feature			•
TC/VTC Electronic speed stabilization			•
<b>Maximum Torque</b>	26.9 inch lbs / 29.2 inch lbs	26.9 inch lbs / 29.2 inch lbs	26.2 inch lbs / 31 inch lbs
<b>Maximum wheel diameter</b>	5" / 6"	5" / 6"	5" / 6"
<b>No-load speed (RPM)</b>	10000 / 9000	10000 / 9000	7000-10500 / 9000
<b>Amps</b>	9.6	9.6	12.2
<b>Rated input watts</b>	1100	1100	1400
<b>Arbor size</b>	7/8"	7/8"	7/8"
<b>Spindle thread</b>	5/8"-11	M14-1.5	5/8"-11
<b>Tool weight</b>	5.8 lbs. / 6.0 lbs.	6.0 lbs. / 6.25 lbs.	6.2 lbs. / 6.3 lbs.
<b>Shipping weight</b>	6.8 lbs. / 7.0 lbs.	7.0 lbs. / 7.25 lbs.	7.2 lbs. / 7.3 lbs.
<b>Length</b>	12.25"	13"	12.25"
<b>Carrying case</b>	344453610 / 656304000 (optional)	656304000 (optional)	344453610 / 656304000 (optional)
<b>Standard Equipment</b>	Side Handle (314000970) Wheel Guard (339203010) / (339203020) Inner Flange (341031290) Outer Nut (316023840)	Side Handle (314000970) Wheel Guard (339203010) / (339203020) Inner Flange (341031290) <b>Outer Nut (316042740)</b>	Side Handle (314000970) Wheel Guard (339203010) / (339203020) Inner Flange (341031290) / (341031850) Outer Nut (316023840) Flange Kit (316037200 - WE14-150 Quick)



# CURRENT MODELS REMAINING IN THE LINE

	Model No.	Order No.	Description
	W6-115	606111420	Wheel Dia.: 4 1/2" 6 amp, 11,000 RPM
	W7-115 Kit	606204820	Wheel Dia.: 4 1/2" 8 amp, 10,000 RPM Comes with case and diamond blade
	WP7-115 Quick	606210420	Wheel Dia.: 4 1/2" 8 amp, 10,000 RPM Lockable paddle switch
	WPS7-115 Quick	606208420	Wheel Dia.: 4 1/2" 8 amp, 10,000 RPM Non-locking paddle switch
	WP7-125 Quick	606211420	Wheel Dia.: 5" 8 amp, 10,000 RPM Lockable paddle switch
	WPS7-125 Quick	606209420	Wheel Dia.: 5" 8 amp, 10,000 RPM Non-locking paddle switch
	WE14-125 VS	601426420	Wheel Dia.: 4 1/2"/5" 12 amp, 3,000-10,000 RPM "Quick" wheel change system Speed stabilization
	WEP14-150 Quick	601452420	Wheel Dia.: 6" 12 amp, 9,000 RPM Non-locking paddle switch Speed stabilization Thermal overload protection

## Choice Cuts™ Slicer Wheels



Job matched thin cut-off wheels from Metabo, the Original Slicer wheel company.

Wheels engineered for every application general purpose cutting to extreme materials

*You can't find a better cut-off wheel!*

US857

1231 Wilson Drive  
West Chester, PA 19380  
800-638-2264 Fax: 800-638-2261  
info@metabousa.com  
[www.metabousa.com](http://www.metabousa.com)

**metabo**<sup>®</sup>  
**work. don't play.**